

Everest Cardio Climber

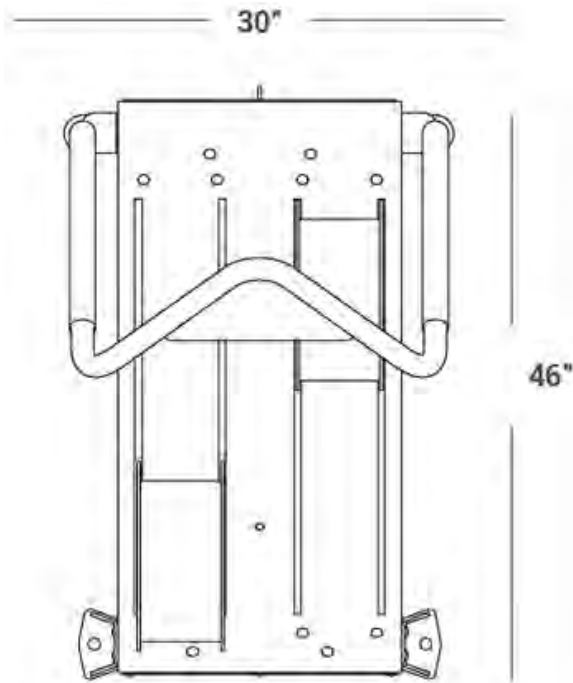

KEY FEATURES

- ✓ One (1) user
- ✓ One (1) station
- ✓ Two (2) exercise modes
- ✓ Weatherproof and tamperproof
- ✓ 15-year warranty



TECHNICAL SPECIFICATIONS

Height: 70" (178 cm)

Fall Height: 84" (213 cm)

Width: 30" (77 cm)

Use Zone: 6'0" x 4'8" (183 cm x 142 cm)

Length: 70" (117 cm)

Weight: 280 lbs. (127 kg)

Shipping Dimensions: 36" (91 cm) W x 80" (203cm) L x 24" (61 cm) H

Shipping Weight: 325 lbs. (147 kg)

Instructional Placards: Reverse print with UV-stabilized ink on 1/4" thick Lexan. Bolted to the columns with a stainless steel trim ring using stainless steel carriage bolts.

Frame: Constructed of 3/16" and 1/4" thick heavy-duty steel. All fasteners are tamperproof stainless steel carriage bolts with a smooth, rounded head and square neck. The locking nuts are shielded behind a padlocked access hatch. Footpads are constructed using heavy-duty aluminum checkered treadplate for anti-slip.

Finish:

- All parts have surfaces prepped and cleaned of all mill scale, rust, oils, and dirt using shot blast and/or chemical wash
- Primer coat is applied with epoxy zinc-rich primer (3-4 mil thickness) and cured in oven
 - Primer designed for superior rust protection. Tested for 3000 hours of salt spray resistance
- Top finish coat is applied with TGIC-FREE weather-resistant polyester powder (3-4 mil thickness) and cured in oven
 - Tested for 1500 hours of salt spray resistance
- All parts inspected to be free of paint defects prior to shipping

Accessibility: It is the manufacturers' opinion that the Everest Cardio Climber conforms to the A.D.A. accessibility standard, assuming an accessible protective surfacing is provided or within the entire use zone.